

MINI-PROJECTEURS TBT ENCASTRÉS

Fixe

HL 100

G 4	20 W 35 W		<ul style="list-style-type: none"> ➤ Corps en acier ➤ Grande variété de finitions ➤ Dorure à l'or fin (finition or) ➤ Pour lampe TBT 35 mm type « MR11 »
12 V			

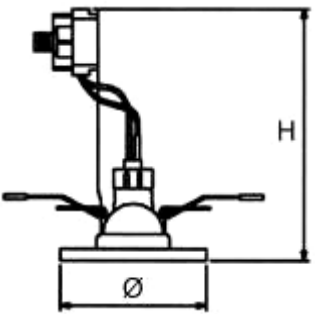



Code	Désignation	U	P	Culot	Dimensions		U.R.
		service			mm	mm	
		V	W		D	H	
100001.0x	SPOT FIXE ACIER 35W	12	35	G4	64	110	40

ÉQUIPEMENTS AUXILIAIRES



➤ Transformateur 230/12V 50VA



➤ Convertisseur 230/12V 50VA électronique



Héliophane sarl

Le Prieuré
2, rue de la mairie
F88600 AYDOILLES

4, montée de Vourlat
F42000 SAINT ETIENNE



courrier@heliophane.com

APPAREILLAGE

MINI-PROJECTEURS TBT ENCASTRÉS

Fixe

HL 10

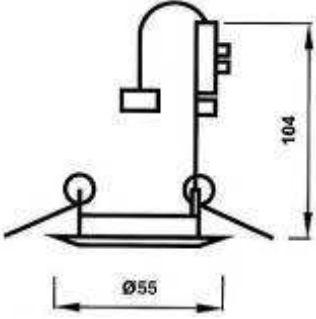
G 4	20 W 35 W		<ul style="list-style-type: none"> ➤ Corps en Zamac ➤ Excellente stabilité en T° ➤ Douille double contact ➤ Grande variété de finitions
12 V			
			



850°C 0,5 m IP 20



Code	Désignation	U	P	Culot	Dimensions		U.R.
		service	W		mm		
		V			D	H	
101001.0x	SPOT FIXE Gu4 35W	12	35	G4	55	104	40

ÉQUIPEMENTS AUXILIAIRES



➤ Transformateur 230/12V 50VA



➤ Convertisseur 230/12V 50VA électronique



Héliophane sarl

Le Prieuré
2, rue de la mairie
F88600 AYDOUILLES

4, montée de Voulat
F42000 SAINT ETIENNE



courrier@heliophane.com

APPAREILLAGE

MINI-PROJECTEURS TBT ENCASTRÉS

Oscillant

HL 109

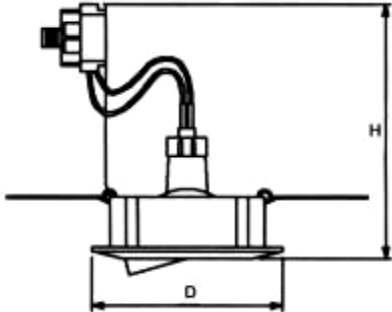
G 4	20 W 35 W		<ul style="list-style-type: none"> ➤ Corps en Zamac ➤ Excellente stabilité en T° ➤ Douille double contact ➤ Grande variété de finitions
12 V			
			



850°C 0,5 m IP 20 III F CE



Code	Désignation	U	P	Culot	Dimensions		U.R.
		service	W		mm		
		V			D	H	
102001.0x	SPOT OSCILLANT G4 35W	12	35	G4	66	104	40

ÉQUIPEMENTS AUXILIAIRES



➤ Transformateur 230/12V 50VA



➤ Convertisseur 230/12V 50VA électronique



Héliophane sarl

Le Prieuré
2, rue de la mairie
F88600 AYDOILLES

4, montée de Voulat
F42000 SAINT ETIENNE



courrier@heliophane.com

APPAREILLAGE

MINI-PROJECTEURS TBT ENCASTRÉS

Fixe

HL 10:

Gu 5,3	20 W 35 W 50 W		<ul style="list-style-type: none"> ➤ Corps en acier ➤ Très grande variété de finitions ➤ Dorure à l'or fin (finition or)
12 V			

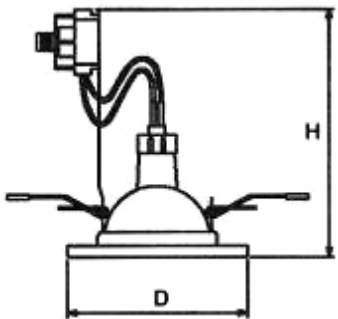

Code	Désignation	U	P	Culot	Dimensions			U.R.
		service	W		mm			
		V			D	H		
103001.0x	ENCASTRÉ FIXE ACIER 50W	12	50	Gu 5,3	80	110	60	20

ÉQUIPEMENTS AUXILIAIRES



➤ Transformateur 230/12V 50VA



➤ Convertisseur 230/12V 50VA électronique



Héliophane sarl

Le Prieuré
2, rue de la mairie
F88600 AYDOILLES

4, montée de Voulat
F42000 SAINT ETIENNE



courrier@heliophane.com

APPAREILLAGE

MINI-PROJECTEURS TBT ENCASTRÉS

Orientable

HL 104

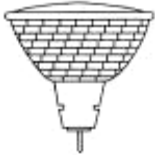
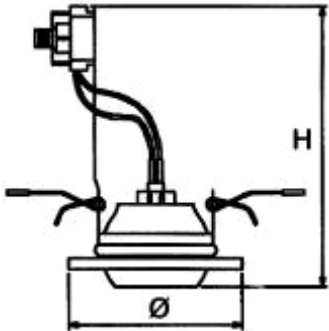
Gu 5,3	20 W 35 W 50 W		<ul style="list-style-type: none"> ➤ Corps en acier ➤ Grande variété de finitions ➤ Dorure à l'or fin (finition or)
12 V			
			



Code	Désignation	U	P	Culot	Dimensions mm			U.R.
		V	W		Ø	H		
104001.0x	MINI PROJECTEUR ENCASTRÉ ORIENTABLE ACIER	12	50	Gu 5,3	105	150	90	12

ÉQUIPEMENTS AUXILIAIRES



➤ Transformateur 230/12V 50VA

➤ Convertisseur 230/12V 50VA électronique



Héliophane sarl

Le Prieuré
2, rue de la mairie
F88600 AYDOUILLES

4, montée de Vourlat
F42000 SAINT ETIENNE



courrier@heliophane.com

APPAREILLAGE

MINI-PROJECTEURS TBT ENCASTRÉS

Fixe

HL 110

Gu 5,3	20 W		<ul style="list-style-type: none"> ➤ Corps en Zamac ➤ Excellente stabilité en T° ➤ Douille double contact ➤ Grande variété de finitions
12 V	35 W		
	50 W		

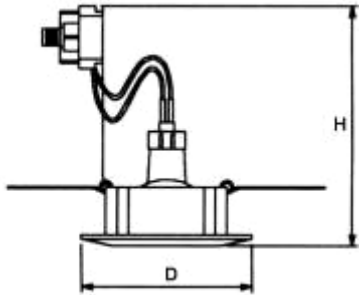

850°C 0,5 m IP 20 III F CE



Code	Désignation	U	P	Culot	Dimensions			U.R.
		service	W		mm	mm	mm	
110001.0x	ENCASTRÉ FIXE ZAMAC GU 5,3	12	50	Gu 5,3	D	H		21

ÉQUIPEMENTS AUXILIAIRES



➤ Transformateur 230/12V 50VA



➤ Convertisseur 230/12V 50VA électronique



Héliophane sarl

Le Prieuré
2, rue de la mairie
F88600 AYDOILLES

4, montée de Voulat
F42000 SAINT ETIENNE



courrier@heliophane.com

APPAREILLAGE

MINI-PROJECTEURS TBT ENCASTRÉS

Oscillant

HL 11

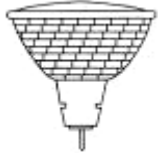
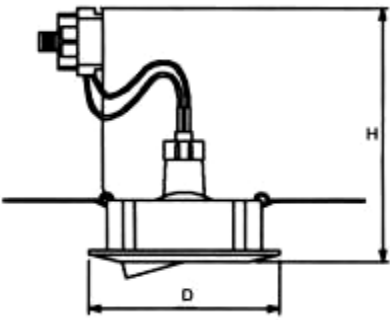
Gu 5,3	20 W 35 W 50 W		<ul style="list-style-type: none"> ➤ Corps en Zamac ➤ Excellente stabilité en T° ➤ Douille double contact ➤ Grande variété de finitions
12 V			
			



30°

850°C 0.5m IP 20 III F CE



Code	Désignation	U service	P	Culot	Dimensions mm			U.R.
		V	W		D	H		
111001.0x	ENCASTRÉ OSCILLANT ZAMAC GU 5,3	12	50	Gu 5,3	86	104	74	21

ÉQUIPEMENTS AUXILIAIRES



➤ Transformateur 230/12V 50VA



➤ Convertisseur 230/12V 50VA électronique

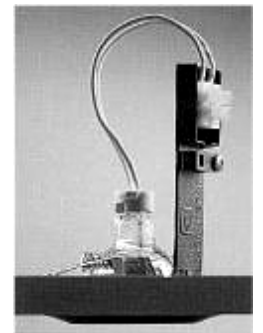

Héliophane sarl

Le Prieuré
2, rue de la mairie
F88600 AYDOILLES

4, montée de Vourlat
F42000 SAINT ETIENNE



courrier@heliophane.com

APPAREILLAGE

MINI-PROJECTEURS TBT ENCASTRÉS

Fixe

HL 113

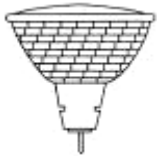
Gu 5,3	20 W 35 W 50 W		<ul style="list-style-type: none"> ➤ Corps en Zamac ➤ Excellente stabilité en T° ➤ Douille double contact ➤ Grande variété de finitions
12 V			

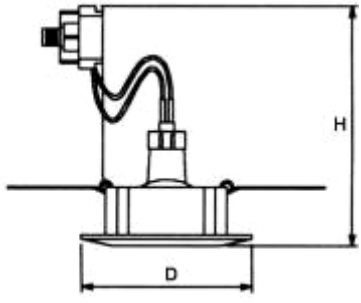

850°C 0,5 m IP 20 III F CE



Code	Désignation	U	P	Culot	Dimensions			Masse	U.R.
		service	W		mm				
		V			D	H		g	
112001.0x	ENCASTRÉ FIXE ZAMAC GU 5,3	12	50	Gu 5,3	78	104	60	130	21

ÉQUIPEMENTS AUXILIAIRES



➤ Transformateur 230/12V 50VA



➤ Convertisseur 230/12V 50VA électronique

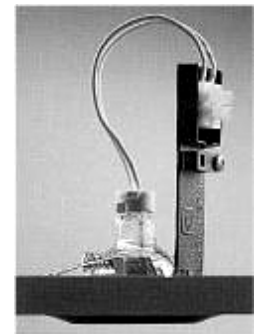

Héliophane sarl

Le Prieuré
2, rue de la mairie
F88600 AYDOILLES

4, montée de Voulat
F42000 SAINT ETIENNE



courrier@heliophane.com

APPAREILLAGE

MINI-PROJECTEURS TBT ENCASTRÉS

Oscillant

HL 11:

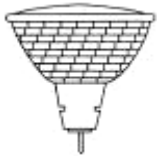
Gu 5,3	20 W 35 W 50 W		<ul style="list-style-type: none"> ➤ Corps en Zamac ➤ Excellente stabilité en T° ➤ Douille double contact ➤ Grande variété de finitions
12 V			

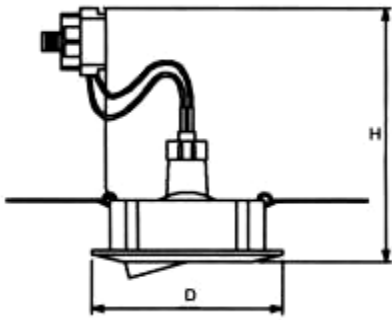

850°C 0,5 m IP 20 III F CE



Code	Désignation	U	P	Culot	Dimensions			Masse	U.R.
		service	W		mm				
		V			D	H	g		
113001.0x	ENCASTRÉ OSCILLANT ZAMAC GU 5,3	12	50	Gu 5,3	81	104	200	21	

ÉQUIPEMENTS AUXILIAIRES



➤ Transformateur 230/12V 50VA



➤ Convertisseur 230/12V 50VA électronique



Héliophane sarl

Le Prieuré
2, rue de la mairie
F88600 AYDOILLES

4, montée de Vourlat
F42000 SAINT ETIENNE



courrier@heliophane.com

APPAREILLAGE

MINI-PROJECTEURS TBT ENCASTRÉS

Basse luminance

HL 117

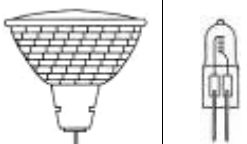
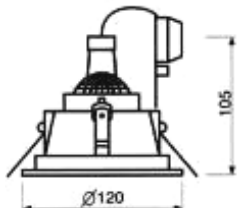
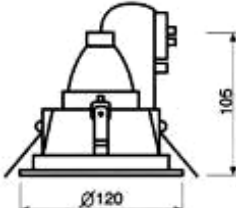
Gu 5,3 Gu 6,35	20 W 35 W 50 W		<ul style="list-style-type: none"> ➤ Corps en Zamac ➤ Très faible éblouissement ➤ Support de lampe basculant
12 V			
			



850°C 0.5 m IP 20 III F CE

Code	Désignation	U	P	Culot	Dimensions			U.R.
		service	W		mm			
		V	W		D	H		
117001.0x	ENCASTRÉ FIXE ZAMAC GU 5,3 BASSE LUMINANCE	12	50	Gu 5,3	120	105	100	1
117002.0x	ENCASTRÉ FIXE ZAMAC GU 6,35 BASSE LUMINANCE	12	50	Gu 6,35	120	105	100	1

ÉQUIPEMENTS AUXILIAIRES



➤ Transformateur 230/12V 50VA



➤ Convertisseur 230/12V 50VA électronique



Le Prieuré
2, rue de la mairie
F88600 AYDOILLES

Héliophane sarl

4, montée de Vourlat
F42000 SAINT ETIENNE



courrier@heliophane.com

APPAREILLAGE

MINI-PROJECTEURS TBT ENCASTRÉS

HL 118

Gu 5,3 Gu 6,35	20 W 35 W 50 W			<ul style="list-style-type: none"> ➤ Corps en Zamac ➤ IP 44 ➤ Support de lampe basculant
12 V				



850°C 0.5 m IP44 III F CE



Code	Désignation	U service		P W	Culot	Dimensions mm			U.R.
		V				D	H		
118001.0x	ENCASTRÉ FIXE ZAMAC GU 5,3	12		50	Gu 5,3	118	118	98	1
118002.0x	ENCASTRÉ FIXE ZAMAC GU 6,35				Gu 6,35				1

ÉQUIPEMENTS AUXILIAIRES



➤ Transformateur 230/12V 50VA



➤ Convertisseur 230/12V 50VA électronique



Héliophane sarl

Le Prieuré
2, rue de la mairie
F88600 AYDOILLES

4, montée de Voulat
F42000 SAINT ETIENNE



courrier@heliophane.com

APPAREILLAGE

MINI-PROJECTEURS TBT ENCASTRÉS

Orientable

HL 12:

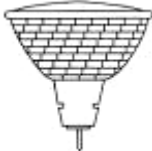
Gu 5,3	20 W 35 W 50 W		<ul style="list-style-type: none"> ➤ De réalisation soignée, cet appareil encastré aux dimensions compactes permet de projeter un faisceau exempt de zone d'ombre. ➤ Agile, il peut être orienté suivant un angle de 40° en site, et 359° en azimut. ➤ Corps en alliage métallique injecté sous pression, douille double contact. ➤ Palette de finitions particulièrement riche.
12 V			

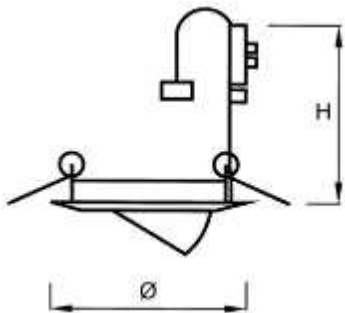



▽ 30° ↻ 355°

850°C 0,5 m IP 20 F CE

Code	Désignation	U	P	Culot	Dimensions			Masse	U.R.
		service	W		mm				
		V	W		Ø	H		g	
123001.0x	ENCASTRÉ ORIENTABLE ZAMAC GU 5,3	12	50	Gu 5,3	110	104	98	340	14

ÉQUIPEMENTS AUXILIAIRES



➤ Transformateur magnétique 230/12V 50VA



➤ Convertisseur électronique 230/12V 60VA



Héliophane sarl

Le Prieuré
2, rue de la mairie
F88600 AYDOILLES

4, montée de Voulat
F42000 SAINT ETIENNE



courrier@heliophane.com

APPAREILLAGE

MINI-PROJECTEURS TBT ENCASTRÉS

Orientable

HL 12'

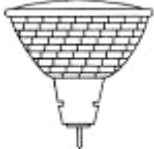
Gu 5,3	20 W 35 W 50 W		<ul style="list-style-type: none"> ➤ De réalisation soignée, cet appareil encastré aux dimensions compactes permet de projeter un faisceau exempt de zone d'ombre. ➤ Agile, il peut être orienté suivant un angle de 40° en site, et 359° en azimut. ➤ Corps en alliage métallique injecté sous pression, douille double contact.
12 V			

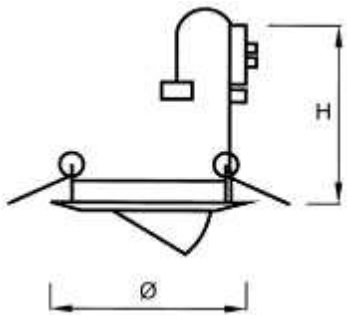



▽ 35° ↻ 355°

850°C 0,5 m IP 20 F CE



Code	Désignation	U	P	Culot	Dimensions			Masse	U.R.
		service	W		mm				
		V	W		Ø	H		g	
124001.0x	ENCASTRÉ ORIENTABLE ZAMAC GU 5,3	12	50	Gu 5,3	102/88	67,5	98	340	14

ÉQUIPEMENTS AUXILIAIRES



➤ Transformateur magnétique 230/12V 50VA



➤ Convertisseur électronique 230/12V 60VA



Héliophane sarl

Le Prieuré
2, rue de la mairie
F88600 AYDOUILLES

4, montée de Voulat
F42000 SAINT ETIENNE



courrier@heliophane.com

APPAREILLAGE

MINI-PROJECTEURS TBT ENCASTRÉS

Extractible

HL 12!

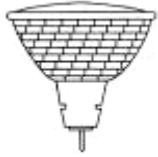
Gu 5,3	20 W 35 W 50 W		<ul style="list-style-type: none"> ➤ « Design » original ➤ Corps en acier ➤ Orientation à 360° ➤ Grande variété de finitions ➤ Dorure à l'or fin (finition or) ➤ Décoratif et efficace
12 V			

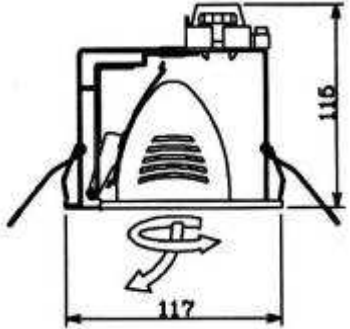



▽ 85° ↻ 355°

850°C 0.5m IP20 III F CE



Code	Désignation	U service		P	Culot	Dimensions mm			U.R.
		V	W			D	H		
125001.0x	MINI PROJECTEUR TBT EXTRACTIBLE	12	50	50	Gu 5,3	117	115	106	1

ÉQUIPEMENTS AUXILIAIRES



➤ Transformateur 230/12V 50VA



➤ Convertisseur 230/12V 50VA électronique



Héliophane sarl

Le Prieuré
2, rue de la mairie
F88600 AYDOILLES

4, montée de Voulat
F42000 SAINT ETIENNE



courrier@heliophane.com

APPAREILLAGE